

# Integration

Nhan Tran

Robert Kernaghan

Philip Richard

# Group Member Responsibilities

- Nhan Tran, Web master
  - Familiarize self with website software
  - Restore website
  - Maintain website

# Group Member Responsibilities

- Robert Kernaghan, Project Manager
  - Coordinate Scheduling
  - Produce Gantt chart

# Group Member Responsibilities

- Philip Richard, Configuration control
  - Coordinate component compatibility
  - Facilitate Pro/E use
  - Solid parts and models administration

Questions?

# Aerodynamics and Heat Transfer

- Lead Engineer
  - Prof. Yaras
- Group Members
  - Aliasger Abdulkadir
  - Joshua Brinkerhoff
  - Wendy Cameron
  - Samir Firfire
  - Darryl Gilbert
  - Saleem Laham

# Cycle Schematic

Compressor inflow conditions are minimum values

Turbine inlet temperature may be higher than 750°C

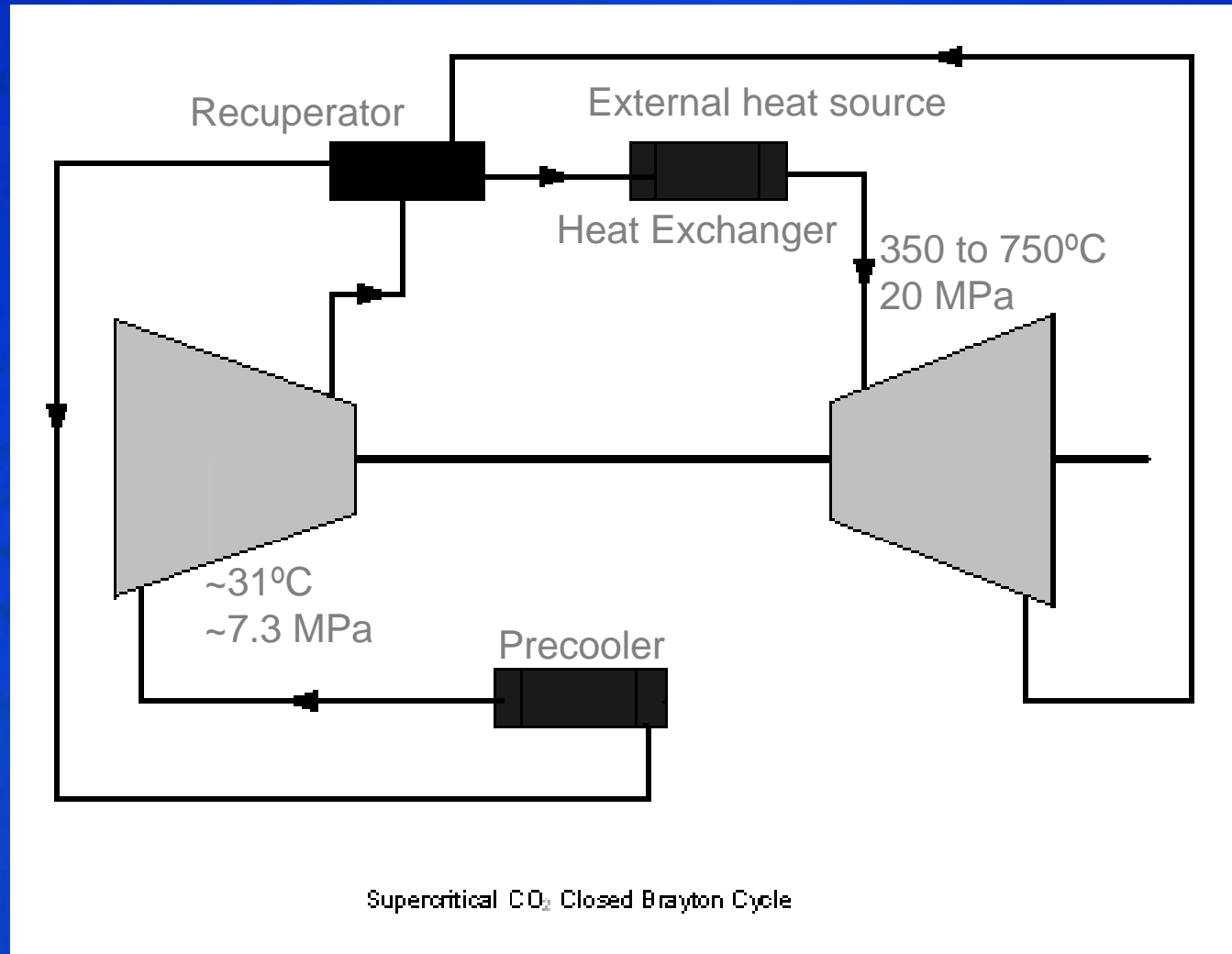

Questions?

# Structures

Josh Armitage

Saad Mousse Guled

Karim Khelifi

# Group Member Responsibilities

- Josh Armitage
  - Mechanical Design
    - Turbine
    - Compressor
    - Casing
    - Shaft
  - Pro E

# Group Member Responsibilities

- Saad Mousse Guled
  - Stress/Strain Analysis (FEA)
    - ANSYS
- Karim Khelifi
  - Vibrational Analysis (FEA)
    - ANSYS

# Weekly Progress

- Observe Aerodynamics Progress
- Research
  - George Franchi (2003-2004)
  - Abigail Kenney (2004-2005)

# Future Goals

- Josh
  - Study Previous Reports – Oct 13, 2006
  - Complete Design of Compressor – Nov 3, 2006
  - Complete Design of Casing – Dec 1, 2006
  - Complete Design of Turbine – Jan 19, 2006
  - Complete Design of Shaft – Feb 16, 2006

# Future Goals

- Saad and Karim
  - Study Previous Reports – Oct 13, 2006
  - Structural Analysis of Compressor – Dec 1, 2006
  - Structural Analysis of Casing – Jan 19, 2006
  - Structural Analysis of Turbine – Feb 16, 2006
  - Structural Analysis of Shaft – March 9, 2006

Questions?

# Performance

Rob Graham

Nicholas Lea

# Team Responsibilities

- Analyze the overall performance of 100MW power plant.
- Model power plant in two different programs:
  - HYSIS
  - C++, Visual Basic, or Mathcad

# Current Work

- Becoming Proficient with Mathcad.
  - Working on example from “Gas Turbine Theory” textbook regarding performance for a heat-exchange cycle.

Questions?

# Advanced Design

Kyle Fridgen  
Megan Rasila  
Matt Ridgway  
Mark McLaughlin  
Gordon MacIsaac

# Group Responsibilities

- Modelling and Optimization of the N<sub>2</sub> Expansion Turbine

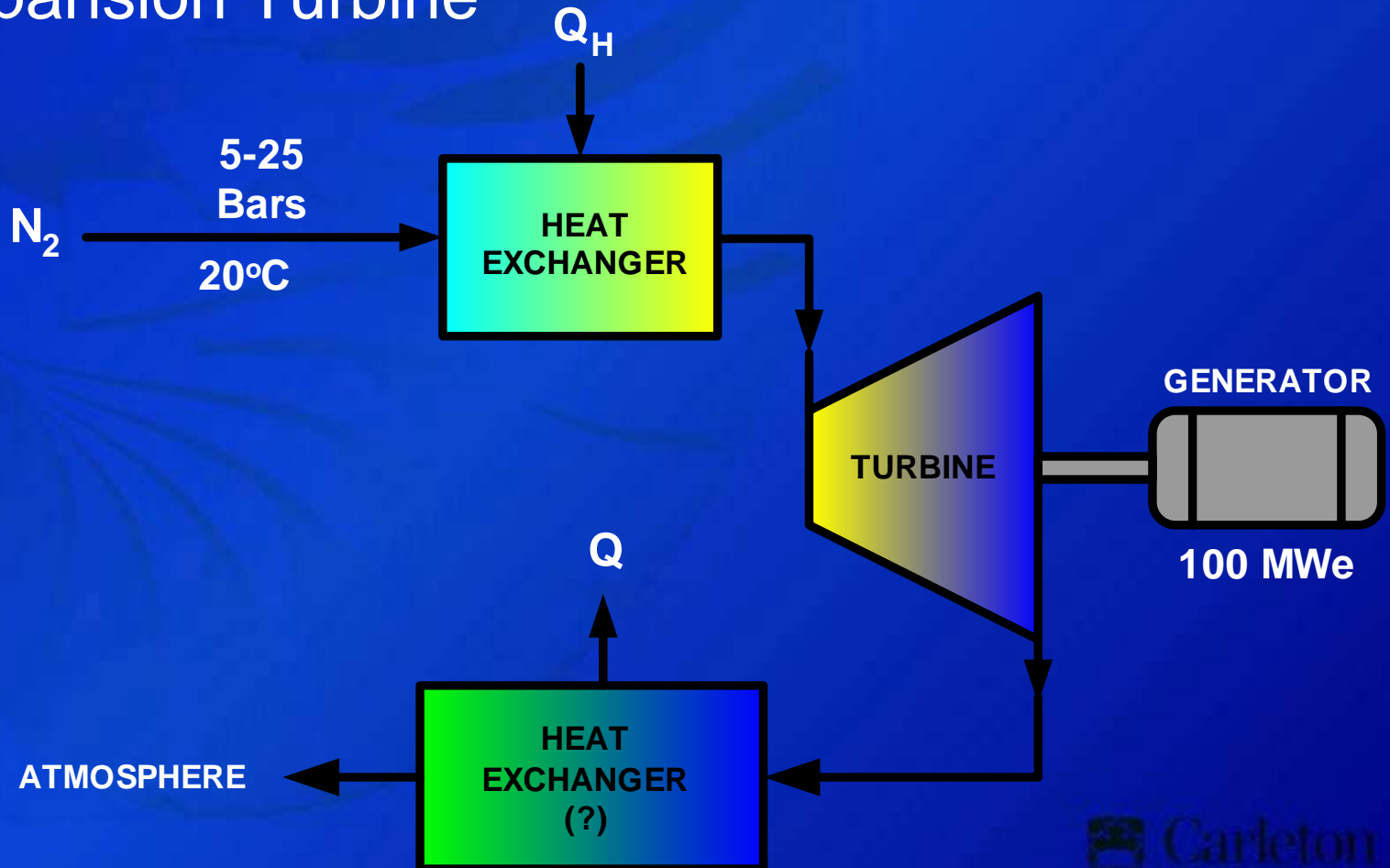

# Individual Responsibilities

## ***Performance*** (Kyle Fridgen)

- Thermodynamic analysis of the system
- Optimization of free parameters
- HYSIS

# Individual Responsibilities

## ***Structures*** (Megan Rasila)

- Turbine preliminary design and analysis
  - Materials (cryogenic)
  - Stress and fatigue
  - Mechanical layout
  - Vibration
- Non-rotating components (ducts, casings)

# Individual Responsibilities

## ***Aerodynamics 1 & 2***

(Mark McLaughlin & Matt Ridgway)

- Design of rotating components
- FORTRAN code (performance prediction)
- Collaboration with NRC

# Individual Responsibilities

## ***Aerodynamics 3*** (Gordon MacIsaac)

- Design of non-rotating components
  - Intake and exhaust (min. losses)
  - Provide undistorted flow to the turbine

Questions?

# Combustion

Gewana Abdelmasih

Ghassan Marjaba

Jason Van Gaal

# Task Organization

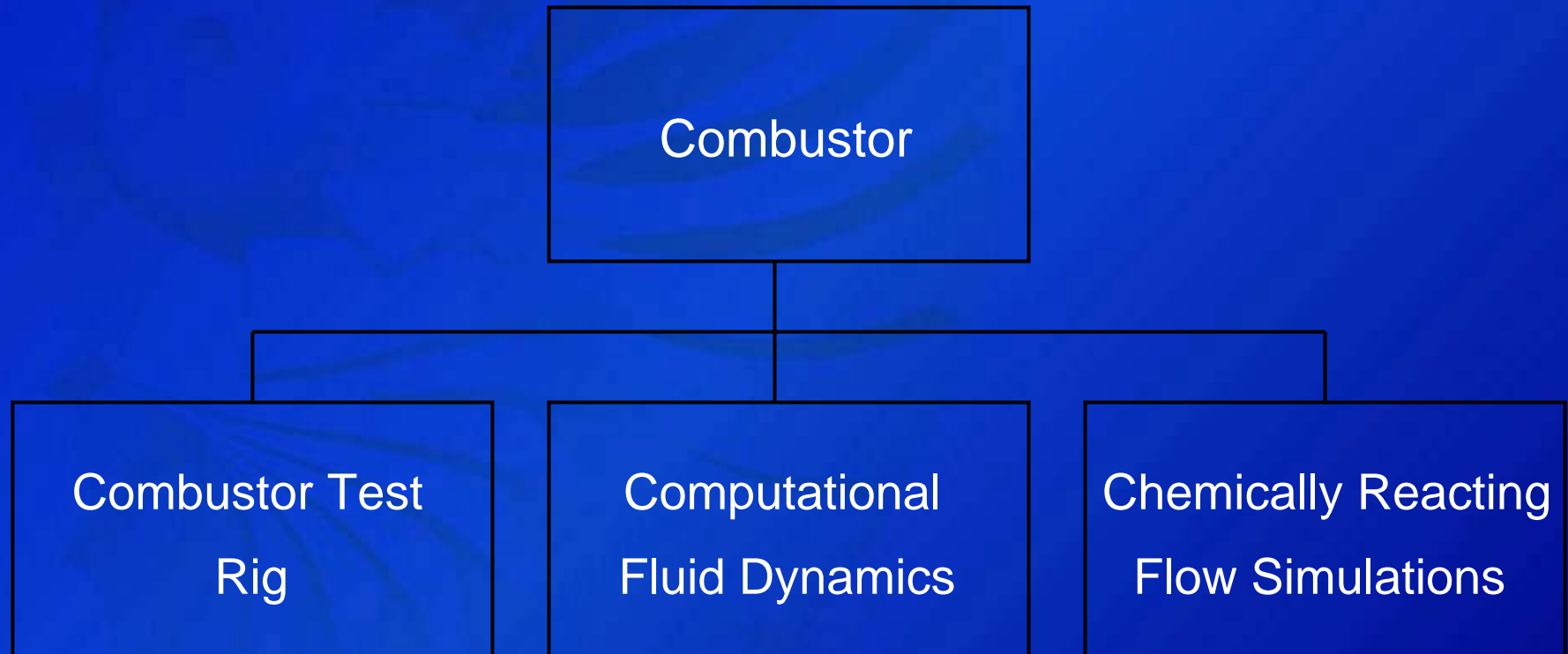

# Combustor Test Rig

Ghassan Marjaba and Jason Van Gaal

- Build, modify and wire the test rig
- Calibrate the instruments
- Perform test runs
- Use LabView for data acquisition and monitoring
- Create ProEngineer drawings of various rig components

# Computational Fluid Dynamics

Ghassan Marjaba and Jason Van Gaal

- CFD modelling of premixer and combustor liner
- ProEngineer drawings of premixer and premixer and liner coupling

# Chemically Reacting Flow Simulations

Gewena Abdelmasih

- Chemically reacting flow modelling using CHEMKIN
- Mixedness simulations of reacting flows
- Gas turbine combustion simulations

# Controls, Electronics & Auxiliaries

- Edward McCarthy
- Tyler Samson
- Kris Knowles

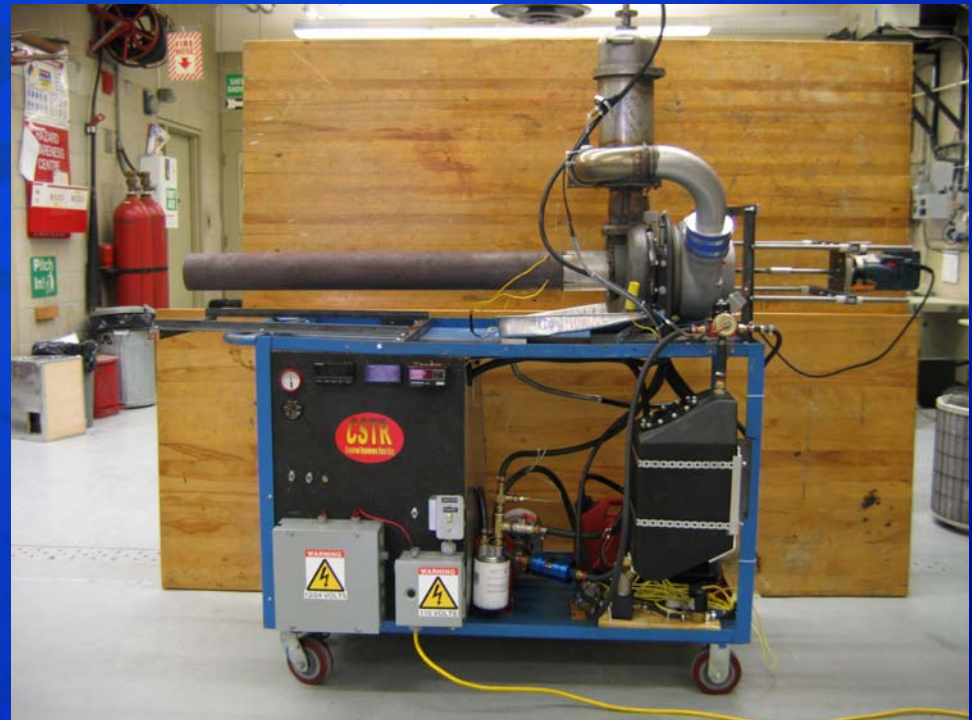

# Main Tasks

- Rig operation and data collection
- Validation of model
- Model improvements
- Signal conditioning
- Thrust measurement
- Automatic disengage of motor

# Recommendations from Last Year (continued)

- Update dynamic models to reflect current cycle design
- Implement the correct turbine map for the CSTR

# Recommendations from Last Year

- Develop and implement a method of measuring thrust:
  - Suspend the CSTR and measure its displacement
  - Install an instrument designed specifically to measure force at the nozzle outlet

# Recommendations from Last Year (continued)

- Develop and implement a method of automatically disengaging the starter motor from the CSTR
  - Possible use of a solenoid
  - Mechanical failsafe for disengage

# Short Term Goals

- Become familiar with rig operation
- Contact Jack or Rob from last years team
- Begin testing of rig and software

Questions?

# Aerostatic Bearing Test Rig

# Aerostatic Journal Bearing Test Rig

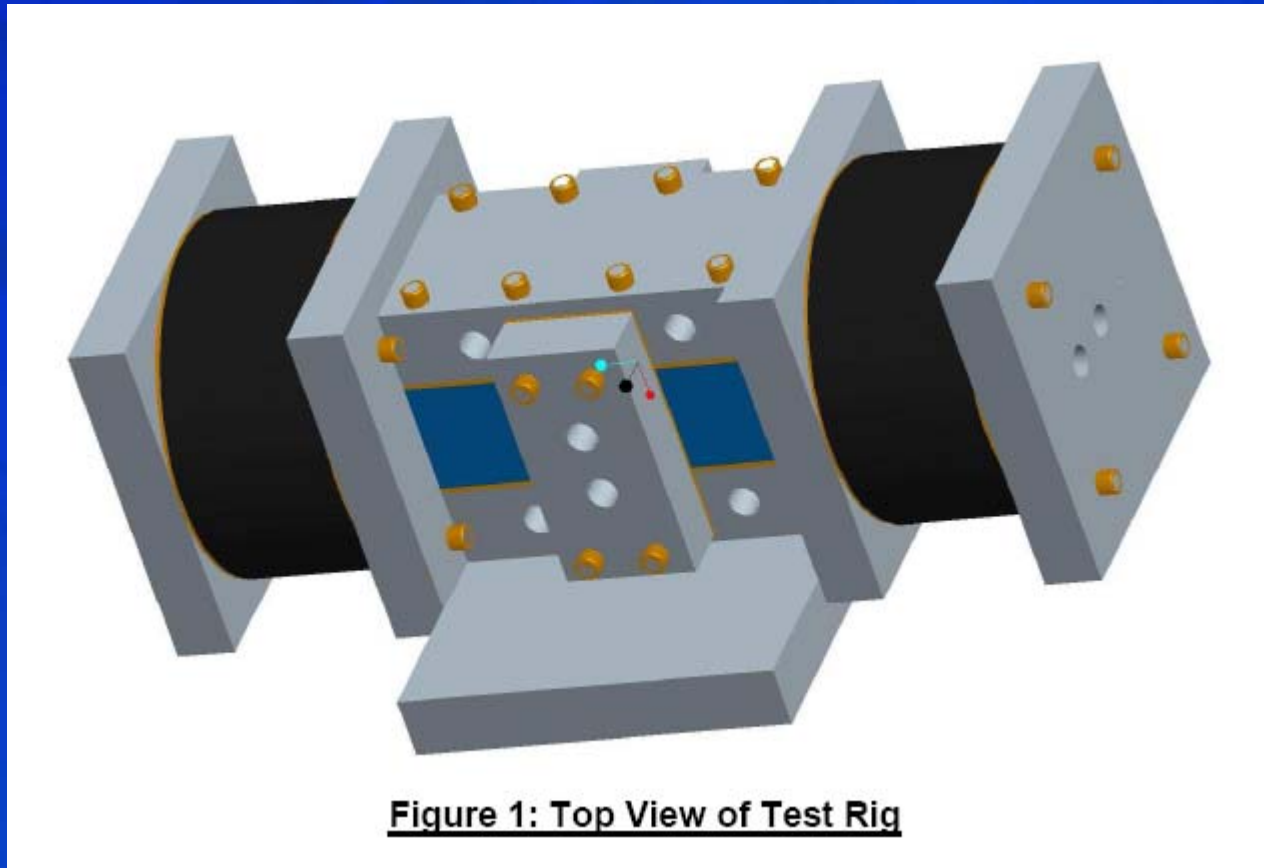

**Figure 1: Top View of Test Rig**

Epp, [DR4907-04GT-280-003](#)

# Aerostatic Bearing Test Rig

## Group Members:

- Matt Stoner - Control systems and test rig safety
- Scott Weir - Fabrication and quality control
- Justin Richardson - Dynamic test rig

# Control Systems and Test Rig Safety

- Leakage issues must be resolved before testing
- CO<sub>2</sub> detection system needs to be installed for safety
- The shaft contact detection system should be improved to include a control system so it can correct errors by applying more pressure to the required area
- Further investigation of hydrostatic bearings.

# Fabrication and Quality Control

- Manufacture bearing blocks and shaft to 0.001in raceway tolerance
- Install thermocouples and pressure gauges to measure the flow rate of the gas delivery system on test rig
- Once successful tests are safely run with CO<sub>2</sub> and we're satisfied that the data is acceptable, fabrication on the dynamic rig shall begin

# Dynamic Test Rig

- Create a test plan for the dynamic setup
- The test rig must be modified so dynamic tests can be completed and appropriate data collected
- A FMEA analysis must be completed for the rotational components since speeds of up to 110,000 RPM must be safely managed
- An appropriate motor or other source of power for the dynamic test rig must be selected

Questions?